



NTT DOCOMO, INC.
Investment in India's
Tata Teleservices Ltd.

November 17, 2008

Forward-Looking Statements

This presentation contains forward-looking statements such as forecasts of results of operations, management strategies, objectives and plans, forecasts of operational data such as expected number of subscribers, and expected dividend payments. All forward-looking statements that are not historical facts are based on management's current plans, expectations, assumptions and estimates based on the information currently available. Some of the projected numbers in this report were derived using certain assumptions that are indispensable for making such projections in addition to historical facts. These forward-looking statements are subject to various known and unknown risks, uncertainties and other factors that could cause our actual results to differ materially from those contained in or suggested by any forward-looking statement. Potential risks and uncertainties include, without limitation, the following:

1. As competition in the market becomes more fierce due to changes in the business environment caused by Mobile Number Portability, new market entrants, competition from other cellular service providers or other technologies, and other factors could limit our acquisition of new subscribers retention of existing subscribers, or may lead to decrease in ARPU or an increase in our costs and expenses.
2. Current and new services, usage patterns, and sales schemes introduced by our corporate group may not develop as planned, which could affect our financial condition and limit our growth.
3. The introduction or change of various laws or regulations or the application of such laws and regulations to our corporate group could restrict our business operations, which may adversely affect our financial condition and results of operations.
4. Limitations in the amount of frequency spectrum or facilities made available to us could negatively affect our ability to maintain and improve our service quality and level of customer satisfaction.
5. The W-CDMA technology that we use for our 3G system and/or mobile multimedia services may not be introduced by other overseas operators, which could limit our ability to offer international services to our subscribers.
6. Our domestic and international investments, alliances and collaborations may not produce the returns or provide the opportunities we expect.
7. As electronic payment capability and many other new features are built into our cellular phones, and services of parties other than those belonging to our corporate group are provided through our cellular handsets, potential problems resulting from malfunctions, defects or loss of handsets, or imperfection of services provided by such other parties may arise, which could have an adverse effect on our financial condition and results of operations.
8. Social problems that could be caused by misuse or misunderstanding of our products and services may adversely affect our credibility or corporate image.
9. Inadequate handling of confidential business information including personal information by our corporate group, contractors and other factors, may adversely affect our credibility or corporate image.
10. Owners of intellectual property rights that are essential for our business execution may not grant us the right to license or otherwise use such intellectual property rights on acceptable terms or at all, which may limit our ability to offer certain technologies, products and/or services, and we may also be held liable for damage compensation if we infringe the intellectual property rights of others.
11. Earthquakes, power shortages, malfunctioning of equipment, software bugs, computer viruses, cyber attacks, hacking, unauthorized access and other problems could cause systems failures in the networks required for the provision of service, disrupting our ability to offer services to our subscribers, and may adversely affect our credibility or corporate image.
12. Concerns about wireless telecommunications health risks may adversely affect our financial condition and results of operations.
13. Our parent company, Nippon Telegraph and Telephone Corporation (NTT), could exercise influence that may not be in the interests of our other shareholders.

Investment rationale

- 1) Capture the promising growth of India and pursue financial returns in the medium term through this investment, while the domestic market is maturing
- 2) Pursue medium term growth drivers through synergies with TTSL (in roaming, enterprise services, branding, joint handset procurement, etc)

Agenda

1. India—one of the world's fastest growing markets

2. Strategic rationale in partnering with TTSL

3. DOCOMO's active involvement in TTSL's operations

4. Achieve medium term returns through capturing the growth of TTSL

Overseas expansion strategy

- DOCOMO continues to look for attractive investments and alliances, particularly in the Asian Pacific region, and is committed to growing DOCOMO's international operations on a global scale

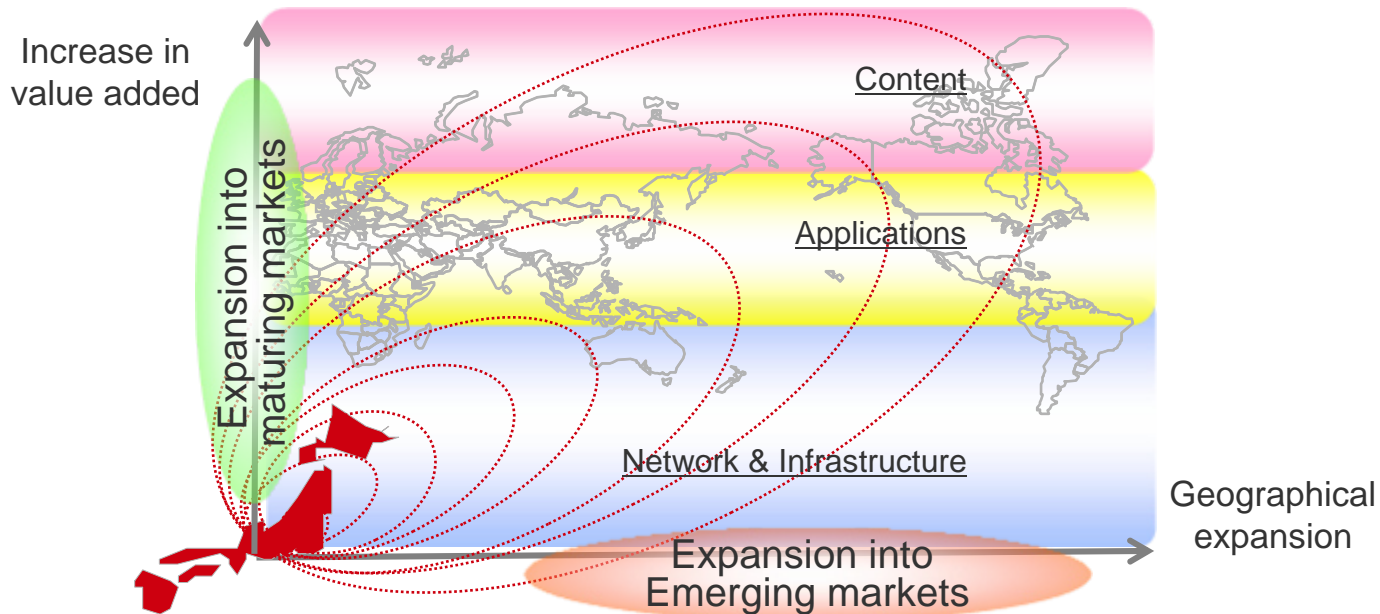

Accelerated growth driven by sharing technical expertise in network building etc.

5 (Ref) Overview of current overseas investments

Major overseas investments

CONEXUS
MOBILE ALLIANCE

HTCL

Dec 1999

Stake: 24.1%

HK, Macao



CONEXUS
MOBILE ALLIANCE

KTF

Dec 2005

Stake: 10.7%

South Korea



NTT
docomo

Tata Teleservices Limited

India

Mar 2009 (Expected)

Stake: 26.0%

This investment



CONEXUS
MOBILE ALLIANCE

Taiwan

FET

Feb 2001

Stake: 4.7%



TM International (Bangladesh)

Bangladesh

Sep 2008

Stake: 30%



Guam

DOCOMO PACIFIC

Dec 2006

Stake: 100%



U Mobile

Malaysia

Mar 2008

Stake: 16.5%



DOCOMO interTouch

Dec 2004

Stake: 100%

Singapore



CONEXUS
MOBILE ALLIANCE

Philippines

PLDT

Mar 2006

Stake: 14.1%



Note: As of Nov 12, 2008

1. India—a fast growing emerging market

India—one of the world's fastest growing markets

Strategic rationale in partnering with TTSL

DOCOMO's active involvement in TTSL's operations

Achieve medium term returns through capturing the growth of TTSL

- Establish a strong presence in India
- Capture a growth opportunity
 - ✓ Penetration of mobile phones in India: Currently*¹ at 30%*² (≈320mm subscribers), and is estimated to grow to 54%*² (≈650mm subscribers) by 2012
 - ✓ Capture growth in the second largest wireless market in the world

*1 Current data as of Sep 2008, *2 Source: Wireless Intelligence.

1-1. Overview of India (Part 2)

◆ Robust growth is expected for both India's economy and its wireless market

(USD) Nominal GDP per capita & GDP growth

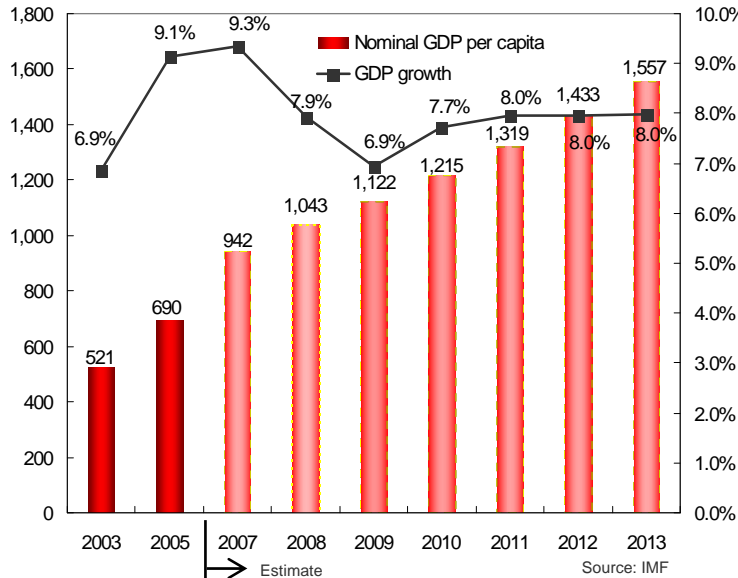

(mm) Subscriber and penetration trends

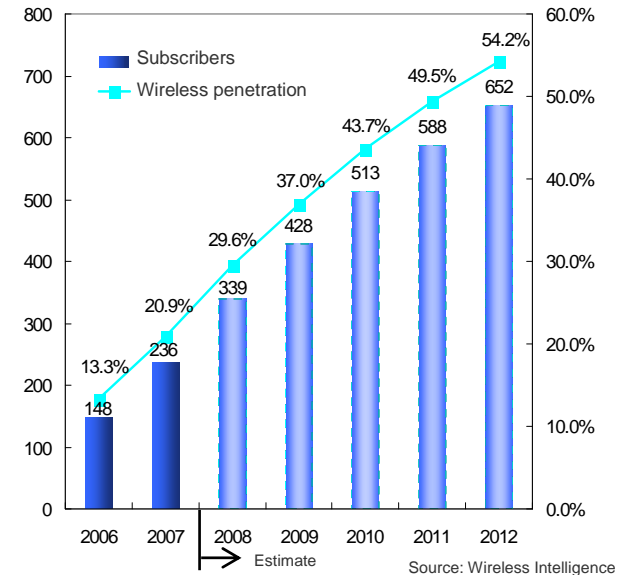

Fundamental economic indicators (2007)

	India	Japan
Real GDP growth rate	9.34%	2.08%
Nominal GDP (USD bn)	1,100	4,382
Nominal GDP per capita* (USD)	942	34,296
Wireless penetration rate	21%	78%

Sources: Wireless Intelligence, IMF * estimate

1-1. Overview of India (Part 3)

India has a steadily growing middle class

(Units: million households)

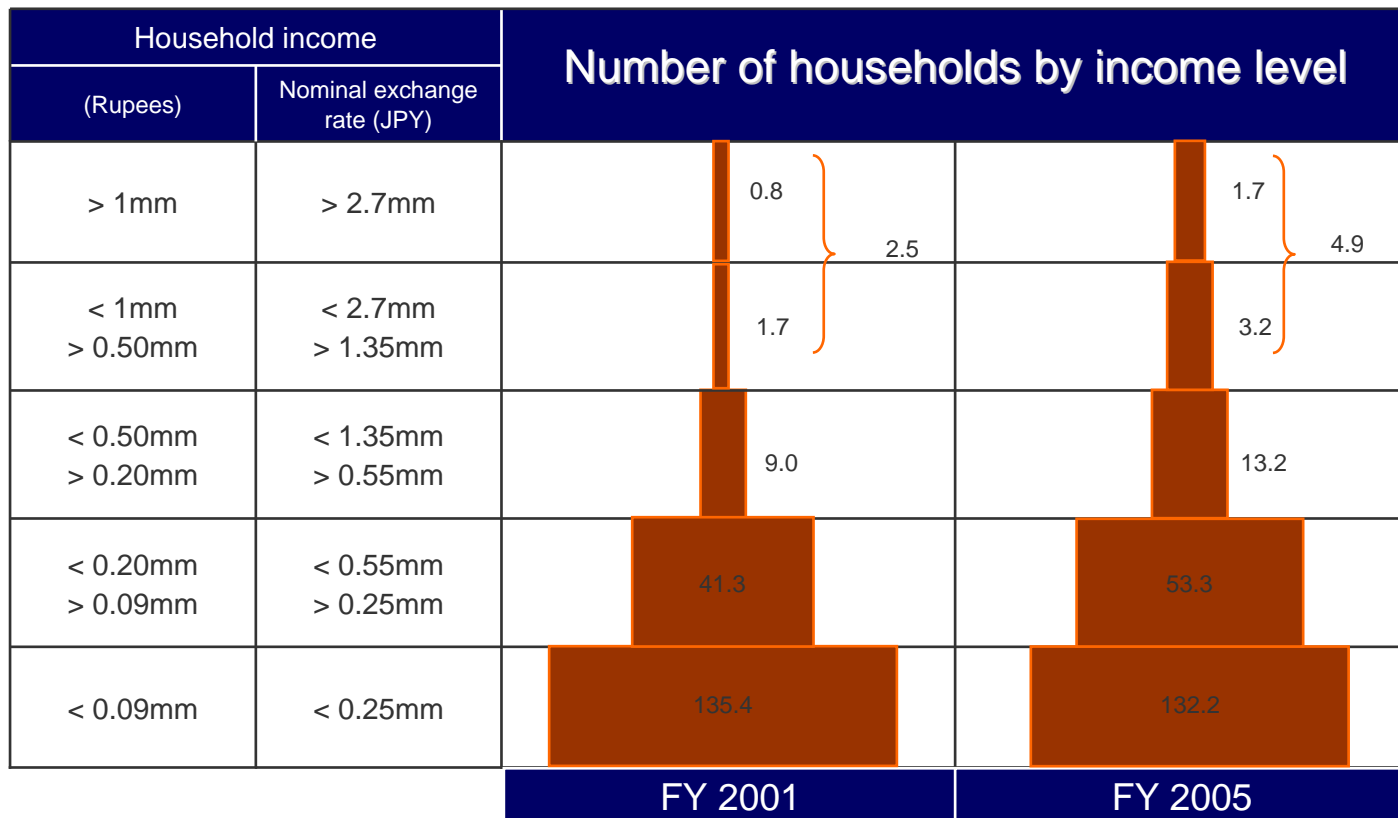

Source: Nomura Research Institute analysis based on National Council for Applied Economic Research (NCAER) data

Note1: Household incomes are in real terms with 2001 as the base year

Note2: INR/JPY exchange rate is INR 1 = JPY 2.73 (approximate figure based on TTS rate as of 2008/3/4)

10 1-2. High growth potential of India's wireless market

- The robust growth of the Indian wireless market may enable DOCOMO to capture growth in the medium term
- Penetration of mobile phones in India is projected to increase from the current*¹ $\approx 30\%$ (320mm subscribers) to $\approx 54\%$ *² (650mm subscribers) in 2012

Subscriber growth (yoy)

*1 As of Sep 2008, *2 Source: Wireless Intelligence

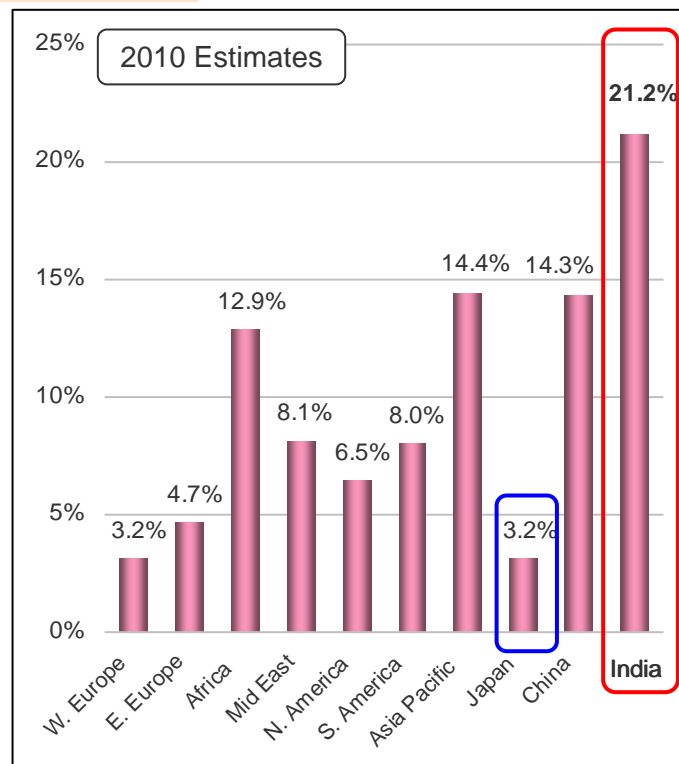
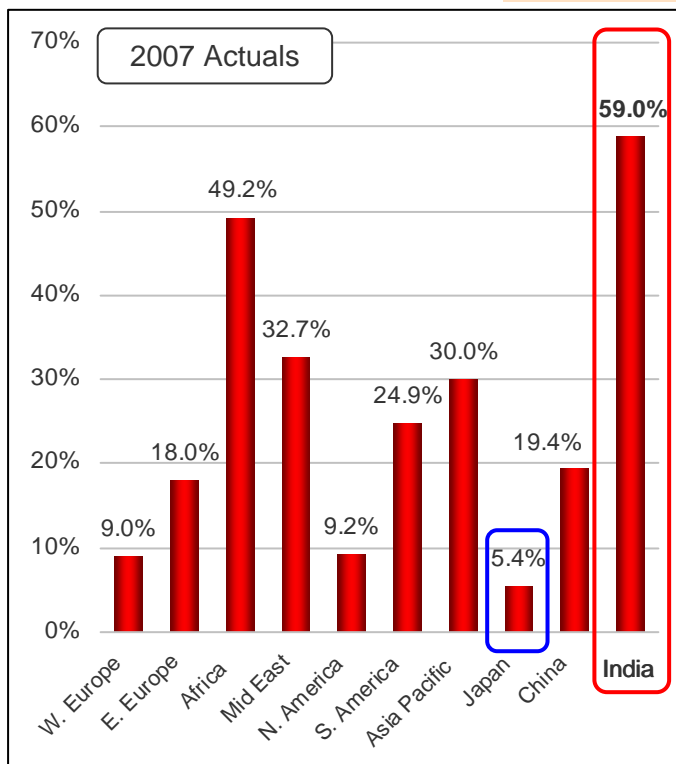

Source: Gartner July 2008 (China and India data as of June 2008)

1-3. Wireless operators in India

Wireless subscribers in India (Sep 2008): 315.3mm

(of which GSM: 233.7mm, CDMA: 81.6mm)

	Subscribers (08/9)	GSM subs (08/9)	Market share	Revenues (08/3)	# circles with existing subscriber base
	(mm)	(mm)	(08/9)	(mm USD)	
Bharti	77.5	77.5	24.6%	5,517	23
Reliance Communications	56.0	9.2	17.8%	3,865	23
Vodafone Essar	54.6	54.6	17.3%	NA	19
BSNL	43.9	39.2	13.9%	7,812	21
IDEA (announced merger)	30.4	30.4	9.6%	1,380	12
TTSL (incl. TTML)*¹	29.3	0.0	9.3%	1,104	20*²
Aircel	13.9	13.9	4.4%	NA	10
Spice (announced merger)	3.6	3.6	1.1%	197	2
MTNL	4.0	3.7	1.3%	918	2
Others (5 players)	2.1	1.7	0.7%	NA	NA

*1 Revenues do not include TTML. *2 Hold license in 23 circles Source: TRAI, COAI, Company information

2. Strategic rationale in partnering with TTSL

India—one of the world's fastest growing markets

Strategic rationale in partnering with TTSL

DOCOMO's active involvement in TTSL's operations

Achieve medium term returns through capturing the growth of TTSL

■ Strategic rationale of the partnership



- ✓ The Tata Group is one of the largest and most highly respected conglomerates in India
- ✓ Significant upside from GSM rollout
- ✓ TTSL may be able to increase its enterprise value even further with the technology and know-how provided by DOCOMO

2-1. TTSL's growth potential—Network

- ◆ High quality network development and maintenance
 - TTSL's network has been granted the highest ratings for quality in the reports of the Telecom Regulatory Authority of India (TRAI)
 - Accumulated engineering know-how by keeping network operations in-house
 - Able to roll out GSM at a significantly lower (30%~40% lower)* cost despite being a new entrant to the GSM market by utilizing existing CDMA facilities

* Estimated by TTSL

- ◆ Over 3,500*¹ exclusive or directly-owned stores
 - Extensive retail and distribution network
 - Has a advantage in capturing the growing telecommunications demand in rural areas where disposable income is increasing
 - Acquire GSM subscribers by leveraging its nation-wide retail and distribution network, while maintaining its current CDMA subscriber base

*1 As of September 2008, source: TTSL internal document

2-3. TTSL's growth potential—Brand

◆ Strong brand recognition *

- TTSL obtained top ratings in all criteria—brand recollection, brand recognition and advertisement
- TTSL's advertisement was ranked No.1 based on the TV audience survey conducted in India's major cities

* Source: Synovate Research (September 2007)

3. Involvement in TTSL's operations

India—one of the world's fastest growing markets

Strategic rationale in partnering with TTSL

DOCOMO's active involvement in TTSL's operations

Achieve medium term returns through capturing the growth of TTSL

- Jointly draw up TTSL's business plan
- Active involvement in the operations of TTSL's business
- Support TTSL's GSM/W-CDMA rollout and aim to accelerate the process

3-1. BTCC* organizational structure

- Business & Technology Cooperation Committee (BTCC*) meetings are planned to be held about twice per year
- Sub-Committees are planned to meet about 7-8 times per year
- Synergies are expected between the NTT Group and Tata Group

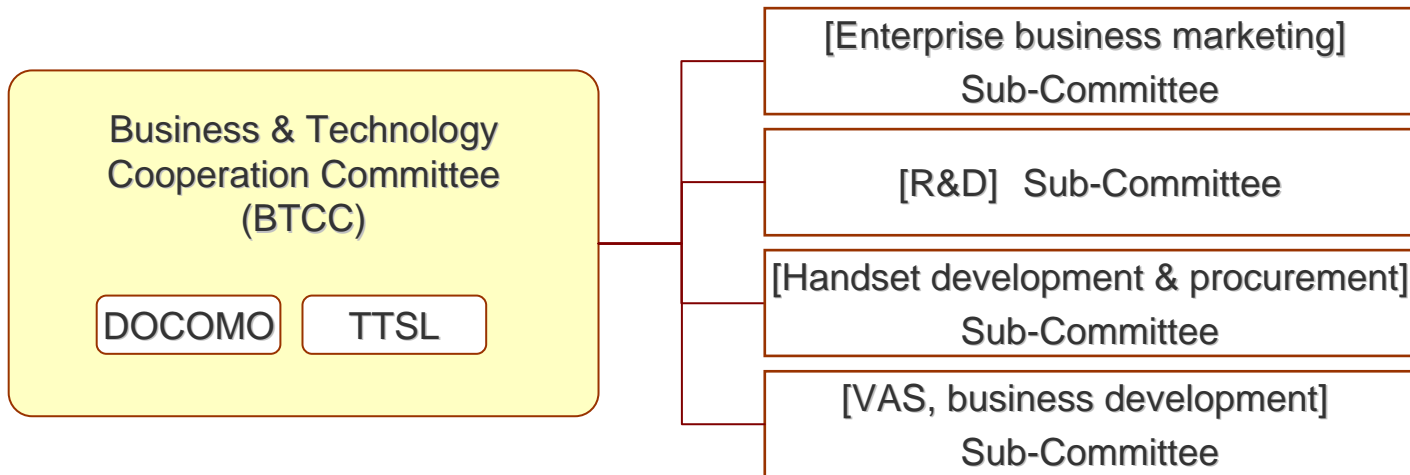

* Headed by a vice-president level member

3-2. Support for the GSM/W-CDMA rollout

TTSL's GSM rollout plan

- Obtained a pan-India GSM license
- Plan to roll out in Jan 2009
- Reduce rollout costs (30~40%)* by utilizing CDMA equipment
- Launch new brand
- Leverage their extensive retail network of 3,500 exclusive or directly-owned stores

Support from DOCOMO

- Support financing for GSM rollout
- Support management and monitor progress
- Advise on W-CDMA rollout
- Introduce a new governance system which facilitates joint management
 - ✓ Establish a network task force
 - ✓ Establish a BTCC

* Estimated by TTSL

DOCOMO believes TTSL has high growth potential, and DOCOMO intends to help accelerate TTSL's GSM rollout with its support

4. Investment rationale

India—one of the world's fastest growing markets

Strategic rationale in partnering with TTSL

DOCOMO's active involvement in TTSL's operations

Achieve medium term returns through capturing the growth of TTSL

- Achieve medium term financial returns through the investment in TTSL
- Achieve medium-to-long term synergies with DOCOMO and the NTT Group as a whole

4-1. Achieve returns in the medium term

- DOCOMO believes this transaction is important for pursuit of mid-to-long term growth drivers in overseas markets
 - ✓ DOCOMO expects the growth of India to contribute to DOCOMO's steady growth, while the domestic market is maturing
- DOCOMO expects to capture the growth of both the Indian market and TTSL on a medium-to-long term basis
 - ✓ TTSL's high growth potential with its high network quality, distribution networks and brand recognition in India is expected to generate medium term returns
- DOCOMO intends to be involved in TTSL's business as an equal partner and promote medium-to-long term collaboration between the two companies through its involvement in the business operations

4-2. Expected synergies

1. Expansion and rollout of enterprise business in India and Japan
2. Take advantage of the increasing network traffic between India and Japan
3. Increase VAS (Value-Added Service) revenues
4. Joint development and procurement of handsets
5. Co-branding and global expansion

NTT
docomo